

# Luxury Boats Shares Now Available!

## BRAND NEW 'Eos' 54FT SEMI-TRAD STERN NARROWBOAT DUE FOR COMPLETION AUTUMN 2011

PHOTOGRAPHS BELOW SHOW NB 'ISIS' AND GIVE AN INDICATION OF QUALITY AND STYLE OF FIT OUT.



**Share Price : £8,250**

**For 4 weeks usage per year, for the lifetime of the boat.**

The syndicate boat is operated by ABC Boat Management who have many years of experience in marina, boat building and hire operations. Allowing you to enjoy the pleasures of boating without the hassles of private ownership. [www.abcboatmanagement.com](http://www.abcboatmanagement.com)

**FOR MORE DETAILS  
CONTACT 0330 3330595 OR EMAIL  
[BOATSHARES@ABCLG.COM](mailto:BOATSHARES@ABCLG.COM)**



ABC BOAT MANAGEMENT

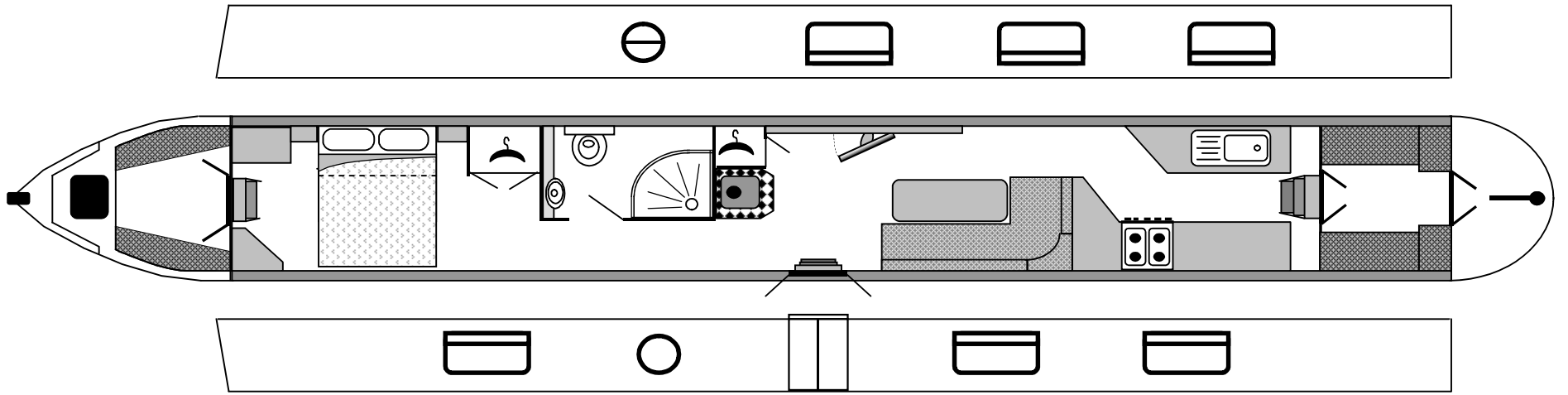



ABC LEISURE GROUP

# Alvechurch Boatbuilders

## Specification for a Fully Fitted Narrowboat

### with a Semi Traditional Stern

#### Hull and Cabin steelwork

**Length** 16.50 metres (54ft)

**Bottom Plates** 10mm.

**Hull Sides** 6mm.

**Cabin sides** 5mm

**Roof** 4mm with 75mm curvature.

**Base Plate Framing** 100 x 75 x 8mm (nominal 635mm centres)

**Knees and stringers** 60 x 60 x 8mm (nominal 635mm centres)

**Cabin roof bearers** 25 x 25 x 2.5mm box section. (nominal 300mm centres)

**Rubbing Strakes** 50mm x 13mm convex - four at bow, three at stern including two full length.

**Diesel Tank-** Integral with hull. Main tank: nominal capacity 225 ltrs. Pressure tested with vent and flame guard fitted.

**Water tank-** Integral with hull, below self draining well deck. Minimum capacity 650 ltrs. Two take off points. Filler on bow deck. Access hatch in bow welldeck

**Gas Locker-** Forward locker of a size to contain two 13kg. cylinders (not supplied) with retainers.

**Weed Hatch-** Quick release type.

**Rudder and tiller-** 50mm dia. stock with tapered top, single bolt fitting. Balanced blade. Swans neck 38mm dia. with brass/wooden extension.

**External doors-** All doors are in steel with painted timber infill panels.

#### Sundries

Bow tee stud, stern two dollies, centre roof ring, plank and pole rack on roof.

Welded steel cants to bow and stern. Traditional Alvechurch style steel handrail.

Four anodes. Hydraulic bow thruster with maintenance access. Anchor & locating bracket. Roof mounted digital TV aerial. A pair of cabin side doors with a hinged roof hatch. All external fittings in chrome finish

#### Painting

The hull will be given two coats of Bitumen based paint up to the top rubbing strake. All other surfaces will be primed followed by an undercoat and a further two coats of gloss. The roof and cabin side surrounds to be Reseda Green – RAL 06011. Cabin side panels to be Chrome Green – RAL 6020. Coach lines – Cream – RAL 1014.

#### Ballast

Ballast will be concrete paving slabs placed under floor as required by design and trim.

## Engine

A Beta Marine Greenline 43 inboard diesel engine will be fitted with hydraulic drive to the propeller and bow thruster unit. The installation package will include:- soundproofing, keel cooling, aqua-drive, flexible mounts, 65 amp. alternator supplying two starter batteries with a separate 170 amp alternator supplying four leisure cabin batteries, Beta type 'AB' control panel with tachometer and hour recorder, keystart switch, and engine default warning lights. Additional panel with voltmeter, water temperature gauge, tunnel light switch, bilge pump switch and horn button. A remote stern tube lubricator and bilge pump would also be fitted. As would a single lever engine control and bow thruster control.

## Insulation

The hull will be lined with 50mm thick flame retardant polystyrene sheet foam and the cabin sides with 25mm thickness.

## Windows and Doors

Silver anodised aluminium drop back vent and fixed windows and portholes are used. All exterior doors are steel fabricated with welded hinges for security. These doors are lined with painted timber panels. The bow doors and bulkheads will incorporate inset windows.

## Ventilation

Ventilation will be fitted in accordance with current legislation, with due regard to appliances and use.

## Internal Linings

Floors are laid in 18mm. (treated) Far Eastern plywood laid on treated bearers. Hull and cabin sides will be lined in 9mm oak veneered plywood. Headlining will be 9mm Ash tongue & grooved hardwood. Bulkheads and internal doors are constructed from 18mm blockboard with oak veneer. All edges are capped in matching hardwood. Finished with four coats of satin varnish on all relevant surfaces. All internal fittings in chrome finish

## Services

**Water** will be supplied by two pressure operated electric pumps and delivered via concealed polybutylene pipework. One pump is for hot water with a 40 litre insulated stainless steel calorifier (heated by the engine and / or the central heating boiler). The second pump with large pre-filter for cold water and a secondary sterilising filter to a separate drinking water outlet in the galley.

**Gas** will be supplied from two 13kg. gas bottles in forward locker via an automatic changeover valve.

**Heating** will be provided by an Alde Compact 3010 LPG fired boiler with a programmable timer. A radiator will be fitted in each cabin (excluding the galley and bathroom). The bathroom will be provided with a radiant towel rail. A 'Becton Bunny' solid fuel stove will be installed in the saloon.

**240 volt electrics** supplied by a 16amp shore line input and 'Victron' 12/3000watt inverter incorporating a 120amp automatic battery charger and supplying a protected ring circuit with two double sockets in each cabin / three double sockets in galley.

## The Interior

**The galley** will incorporate a slot in gas oven and grill with a four burner hob. Extractor fan. A 113 litre, 12-volt electric refrigerator. Base units with cupboards and drawers under composite postformed work tops with under mounted stainless steel sink, drainer and mixer tap. A microwave oven will also be supplied and fitted. Corner units will incorporate 'magic corner' sliding accessories.

**The Bathroom** will include a quadrant shower with a laminated easy clean surround, sliding doors and an electric shower emptying pump. A vanity unit with a semi-recessed basin will be fitted together with a Tecma fresh water flush, macerator toilet and a remote polypropylene holding tank. Extractor fan.

**Bedroom** as per plan; will include a sliding cross double bed with a slatted base, minimum width 4ft 6inches wide. Above bed cupboards and shelves. Dressing table, low level cupboards with TV aerial point.

**The Saloon / Dining** as per plan; will include a 'L' shaped dinette / double berth with storage under. Low level shelving to include fitted stereo radio/CD player with mp3 input and a 26 inch LCD TV with digital tuner and a DVD player.

## Interior sundries

Curtains and blinds, track and retainers. Galley and Bathroom fitted with 'Polysafe' flexible vinyl safety flooring, all other floor areas are fitted with high quality oak veneered wood laminate. Ceiling and wall mounted halogen and low level LED Lighting.

## Safety and Navigation Equipment

Bow, stern and two side fenders will be fitted and three mooring lines supplied. One boarding plank, boat pole, boat hook and shaft. Three fire extinguishers and a fire blanket will be fitted internally.

## All boats

All boats are supplied with documentation in accordance with the European Recreational Craft Directive and UK Boat Safety Scheme requirements.

**NEW SHARED OWNERSHIP BOAT**  
**APPROXIMATE BUDGETED ANNUAL RUNNING COSTS**  
**(based on a 54ft Semi-Trad)**

<b>ITEM</b>	<b>ANNUAL COST</b>
Moorings	£2,000
Licence	£680
Insurance	£250
Weekly Turnround Service	£1,750
Oil Changes/Serviceing	£475
Equipment Repairs	£350
Breakdowns	£200
Inventory & Replacements	£250
Gas	£800
Miscellaneous	£250
<b>TOTAL PER BOAT PER ANNUM</b>	<b>£7,005</b>
<b>TOTAL PER 8% SHARE PER ANNUM</b>	<b>£560 (a)</b>
Annual Management Fee (Current)	<b>£250 (b)</b>
Annual Winter Maintenance Costs (approximate - Yrs. 1 & 2)	<b>£150 (c)</b>
Other Variable Costs (approximate) (Fuel & Pump Out)	<b>£500 (d)</b>
<b>Total Annual Costs (approximate)</b>	
<b>Budgeted Running Costs - as above</b>	<b>£560 (a)</b>
<b>Annual Management Fee - as above</b>	<b>£250 (b)</b>
<b>Annual Winter Maintenance - as above</b>	<b>£150 (c)</b>
<b>Other Variable Costs - as above</b>	<b>£500 (d)</b>
<b>TOTAL COSTS (APPROXIMATE) PER 8% SHAREHOLDING PER ANNUM</b>	<b>£1,460</b>
<b><u>MONTHLY COST - [(a), (b) &amp; (c)] above</u></b>	<b><u>£80.00</u></b>
<b><u>VARIABLE COST PER WEEK OF USE - (d) above</u></b>	<b><u>£125.00</u></b>



## **SHARED OWNERSHIP – FREQUENTLY ASKED QUESTIONS**

### **How many names can I have on my Share Certificate?**

Up to four people can be named on a share certificate. This would cover either two lots of close friends who often holiday together, or for example, mum, dad and two grown up children. Once their children have reached the age of 25 they would then be able to take the boat out themselves with their own families. Please remember that one named owner must be with the boat at all times.

### **How often can we use the boat?**

Each shareholder is allowed a minimum of four weeks use per year. The concept is based on the Syndicate members being joint owners of the boat and sharing the year between them on a lot drawing basis each year, as described. This has two advantages. Firstly, no-one is tied to taking the boat out in the same weeks every year and secondly, it is possible to take the boat out for a minimum of four weeks each year. However, for those who want longer cruising there is no reason why, with agreement, you cannot use unwanted weeks of other members of the Syndicate during the year.

### **Can I have two weeks together?**

Yes, and this is often achieved in many Syndicates. You will achieve this by swapping your weeks around with other owners, either at the AGM after the draw or at any time during the year over the telephone. Just advise the Admin Office of any changes to your allocation of weeks so that the master chart can be updated.

### **How long do the Syndicates stay in existence?**

There is no fixed time for the life of a Syndicate but this is most certainly NOT one of the five year only schemes. The life span of these boats is virtually unlimited because they have all been very well built and are receiving regular weekly maintenance during their life. They are cleaned weekly, kept well aired and warm and undergo an annual maintenance programme. Replacement of items such as cookers, carpets, upholstery, fridges etc. over the years means that the boats are kept well and truly up to scratch. Over

90% of the Syndicate must be in agreement before the boat can be sold. If such a decision is taken the boat could be offered on the open market by ABC Leisure Group, and receipts from the sale would be split between the owners in proportion to their shareholding.

### **Can I sell my share in the boat?**

If you decide for whatever reason that you no longer wish to keep your share in the boat, then ABC Boat Management will re-market the share for you free of charge. This is a service which we believe is unique to ABC Boat Management, as other management companies will take commission from the sale.

### **Is there a Syndicate Agreement?**

A formal agreement is drawn up between each owner and the syndicate who contract ABC Leisure Group as the management company, or in some syndicates it may be each owner that signs directly with ABC Leisure Group. This is designed to protect the interests of all the owners and covers points that can arise in the operation of the Syndicate. It has been designed to be fair, non-contentious and to protect the interests of members of the Syndicate. Several of our owners are solicitors who have themselves looked through the agreement and been satisfied to proceed.

### **Who looks after the boats?**

ABC Leisure Group contract with operational bases for the provision of permanent moorings, operational and engineering support, and maintenance and service of the boats. Although not a requirement to do so, some boats do operate from ABC Leisure Group owned bases for which they receive a discount on the management fees. ABC Leisure Group also arranges for a predetermined winter maintenance programme to be carried out annually. When on the boats, the owners have full engineering support available in the unlikely event that this is required.

### **Will I meet other members of the Syndicate?**

Each year owners meet at the Annual General Meeting for the Syndicate. Formal discussions take place and the draw of weeks for future use of the boat is undertaken. It is also an opportunity to get to know fellow owners in a social setting over a meal and a drink. Each member is provided with details of other members of their own Syndicate.

### **Can I take friends along with me?**

Yes of course you may, just as if you were the sole owner of the boat. The only restriction is that you or a named shareholder must be with the boat at all times as you will have the responsibility for it.

### **May the boat be hired out or offered for skippered hire?**

A definite 'NO'. there must be a shareholder on board the boat at all times and the boat MAY NOT BE HIRED OUT OR OFFERED FOR SKIPPERED HIRE. If however you are unable to use the boat, you may either swap with another owner or, if this is not possible or required, the unused time may be offered for use to another member of your Syndicate through the Administration Office. You yourself may also be able to take up unused weeks from other owners giving you more time on the boat for which to take up unused weeks from other owners giving you more time on the boat.

### **How are the weeks allocated?**

The year is divided into four periods to cover Spring, Summer, Autumn and Winter seasons and 'lots' are drawn from each of the groupings every year thus enabling everyone to have a selection of weeks throughout the year. Should one Syndicate member want time drawn by another member it will be possible to exchange weeks or merely offer them over if not required. UNUSED WEEKS CANNOT BE SOLD, LET OR HIRED TO ANYONE ELSE. Allocation of weeks is by annual ballot.

### **Can weeks be swapped with other members of the Syndicate?**

Once the initial allocation has been made each year, members may then swap and change about in order to increase their time allocation or obtain consecutive weeks. All that is asked of you is that you keep the Administration Office advised of any swaps that you have made.

### **What is my investment going to be?**

Each owner pays the share price applicable to the Syndicate they are joining. They usually purchase four weeks which represents an 8% shareholding and this will be a life ownership which can be bequeathed to their heirs.

### **Is this a time-share scheme?**

Only in so far as the weeks during the year are shared between all the Syndicate members. In every other aspect it is totally different. You do not have the same fixed weeks each year. The share price does not vary according to when you take your holiday. There is no limit on how many weeks you actually take if they are available. Your only extra on-cost is for the diesel and pump out per week. You are not tied to one start point. The company is not linked to an international exchange organisation. Finally and most importantly, you own title to your share in one specific named boat and use of that boat is restricted solely to the named owners within that Syndicate.

### **Why should I not go out and buy a boat for myself?**

Apart from the sheer amount of capital outlay, there are several reasons for not being the sole owner of such a boat. These vary from the total

responsibility and worry if you have not visited it recently to the actual cost of paying for the moorings, insurance, licensing and maintenance. In our experience boats like to be used – they look brighter, have less operational problems and do not deteriorate as fast if they are used, cleaned and generally moved around throughout the year. It is a fact that most boat owners, unless they are living aboard, use their boats for a maximum of 2-3 weeks per annum. Between 15-20% of our owners buying shares have in fact at some stage been boat owners themselves.

### **Where will the boat be based?**

ABC Leisure Group offer a great variety of their own bases from which to operate on the UK Canal system or can arrange for other location if required. At the AGM each year the Syndicates may choose another location for the next year or longer. This system offers a great selection of cruising g areas and the ability to move around the canal system as much as they wish.

### **Where can I go with the boat?**

The owners are able to organise one way trips between themselves whereby one owner takes the boat on the outward trip, they arrange a point at which to swap over and the second owner returns to the operating base. Any additional charges incurred, such as mooring charges, are the responsibility of the parties involved.

### **What is expected?**

Every syndicate member is responsible for the boat whilst it is under his/her control and for any self inflicted damage such a cilling, damage to the carpets or upholstery and broken windows. Any general problems that arise will be covered by the Syndicate fund. At the end of each holiday period the Syndicate member is responsible for fuelling, gassing, pumping-out and cleaning the boat so that is left spick and span for the next owner.

### **What happens if the boat has a breakdown?**

If you are on the boat and you have a breakdown that you are unable to fix yourself, you would make contact with the relevant designated call-out service for that area. If for some unforeseen reason your home boatyard is unable to help you, you should immediately contact ABC Leisure Group. Once the breakdown has been carried out the cost would be billed to the Admin Office for payment out of the Syndicate account. In the event that you are a long way from home base and had to pay cash for the breakdown, this would be reimbursed to you from a central fund. This fund is set up each year to cover the costs of breakdowns during the year. With regular maintenance these should be minimal and any excess funds at the end of the year would be rolled over to the following year. Payment for self-inflicted damage will always be the responsibility of each individual member.

### **What happens if a Syndicate member breaks any of the rules?**

Our Syndicate Agreement gives clear guidelines as to what happens if there is a contravention of the rules. The ultimate sanction is that the owner would be asked to leave the Syndicate.

### **What inventory is included on the boat?**

The boats are equipped with a very comprehensive inventory which is listed in this presentation. The only items that are not supplied are sheets, duvet covers, pillow cases and towels which are the individual responsibility of each owner for their own trips. When inventory is broken the operating base will keep a small stock of replacement items. There is a price list and an honesty box at each base and all an owner has to do is to replace the item on board or leave the money to cover the cost of it.

### **What colour will the narrow boats be?**

The boat can be any colour the Syndicate chooses.

### **What annual work will be carried out on the boat?**

It is necessary to have certain tasks undertaken on an annual basis. These include engine servicing and appliance servicing including the cooker, central heating boiler and fridge. The paintwork has to be touched up every year and a full repaint is probably required every two/three years. There is also an annual spring clean to include upholstery, carpets and curtains. The organisation of this annual refurbishment programme is the responsibility of ABC Leisure Group, in close liaison with the Admin Office.

### **Who pays the annual maintenance?**

The cost of the maintenance work is proportional to each member's shareholding. A purchase of four weeks means that the member contributes 8% of the annual costs. All the work carried out is to formally produced schedules and invoiced separately from the operating costs and admin fee.

### **Are the boats insured?**

The boats are fully insured up to full replacement value. Each owner is responsible for the excess which is usually between £250 - £500 dependant on the insurance the syndicate has chosen for any damage caused during his control of the boat. Any claims above this amount are covered by the boat insurance policy, and there is a third party liability limit of £1m. There is no cover for personal possessions or personal accident.

### **Would I be allowed to bring pets?**

Yes, but we are afraid you will have to supply your own as we do not provide them. Your boat is equipped with a Dyson vacuum cleaner with dual filters, which is a great help when preparing the boat for the next owner. If you

have had a pet with you during your week on the boat please remember to allow extra time for your cleaning.

**Do you operate a 'no smoking' policy on the boats?**

No we do not. However, it would appear that only a small percentage of our owners do smoke and most would appear to do it in the open air, either on the fore deck or the back deck.

**Do owners have any control over operation and administration costs?**

Yes, through their decision making and input at the AGM. Owners are presented annually with summaries of the income and expenditure for their Syndicate. ABC Leisure Group put no mark up of any sort on to any operational or maintenance costs and all owners pay the NETT costs.

**Do you allow children and would I be guaranteed school holidays every year?**

Children are welcome as part of your family. School holidays are not guaranteed for any owner but we try to restrict each boat so that not more than two owners requiring school holidays buy a share in each boat. At the annual draw, we ask other owners to co-operate when the draw is carried out by swapping school holidays that they have drawn with those who specifically need them. Most owners who want them normally get them. One of the specific reasons for this is that many of our owners DO NOT want school holidays, and if they draw them they are only too happy to swap.

**How many shares can I buy in a boat?**

The maximum number of shares an owner can buy in any one boat is two. This prevents one person having too much control over decision making in a Syndicate. For those owners wishing to purchase more than two shares they would have to buy them on different boats or even in different waterways if they wanted.

**What happens if all of the shares in the boat have not been sold by the time the boat is launched?**

If in the unusual circumstance that all the shares have not been sold in the boat by the time it is launched, it will have no impact on your agreed purchase price or the monthly payment towards running costs. Shares brought after the launch date will still be liable for the full years contributions, but, if for any reason these not sold in the first year or this is not reasonable, ABC will cover the whole or missing part of the running cost contributions.

